

Changhong CHiQ

User Guide

CH7804-UC

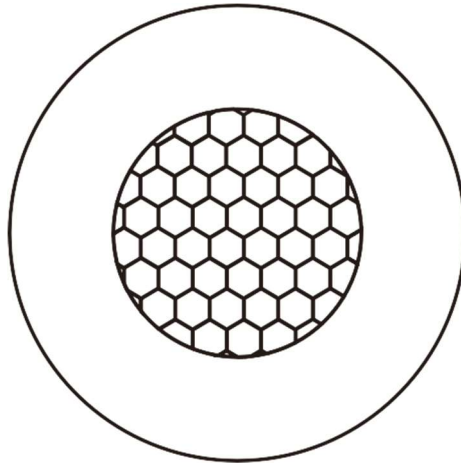

Motion Sensor

Contents

Introduction	1
Features	2
Product Requirements.....	2
What's in The Box	2
Set Up Motion Sensor	3
Installation.....	7
Using CHiQ App with Motion Sensor	10
CHiQ Control.....	12
Maintaining the Motion Sensor	15
Specifications	17
Troubleshooting	18
Customer Service & Warranty	19

Introduction

Motion Sensor is widely used in moving human body detection. Download CHIQ App, add Motion Sensor to your smart home system, which will be able to monitor your home's security in real time.

LED lights can show the current status of device. See the explanation below:

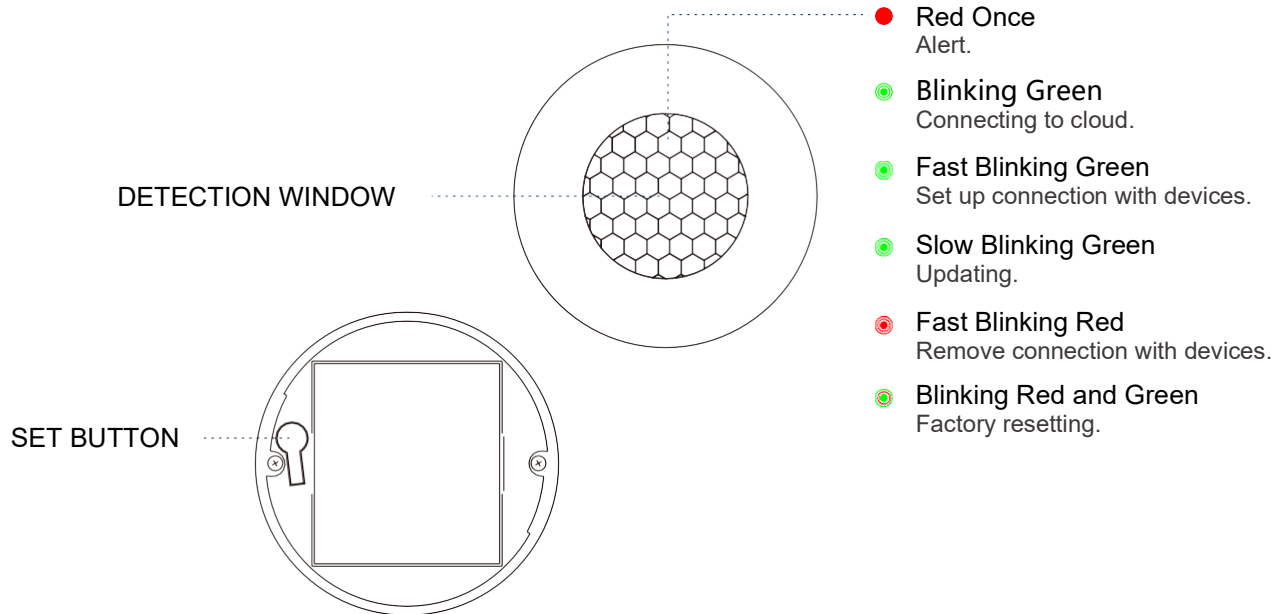

Features

Real-time Status - Monitor the real-time state of movement via CHiQ App.

Battery Status - Update battery level and send low battery alert.

CHiQ Control - Trigger an action of certain CHiQ devices without internet.

Automation - Set up rules for “If this then that” function.

Product Requirements

- A CHiQ Hub.
- A smartphone or tablet running iOS 9 or higher; Android 4.4 or higher.

What's in The Box

- Qty 1 - Motion Sensor
- Qty 2 - Screw
- Quick Start Guide

Set Up Motion Sensor

Follow the steps below to set up your Motion Sensor via CHiQ App.

Step 1: Set up CHiQApp

- Get the CHiQ App from the Apple App Store or Google Play.





Step 2: Log in or sign up with CHiQ account

- Open the App. Use your CHiQ account to log in.
- If you don't have a CHiQ account, tap **Sign up for an account** and follow the steps to sign up an account.



Step 3: Add device to CHIQ App

- Tap the “” in CHIQ App. Scan the **QR Code** on the device.
- You can customize the name, set the room, add to/remove from favourite.
 - a. **Name** - Name Motion Sensor.
 - b. **Room** - Choose a room for Motion Sensor.
 - c. **Favourite** - Click “” icon to add/remove from Favourite.
- Tap the “Bind Device” to add the device to your CHIQ account.

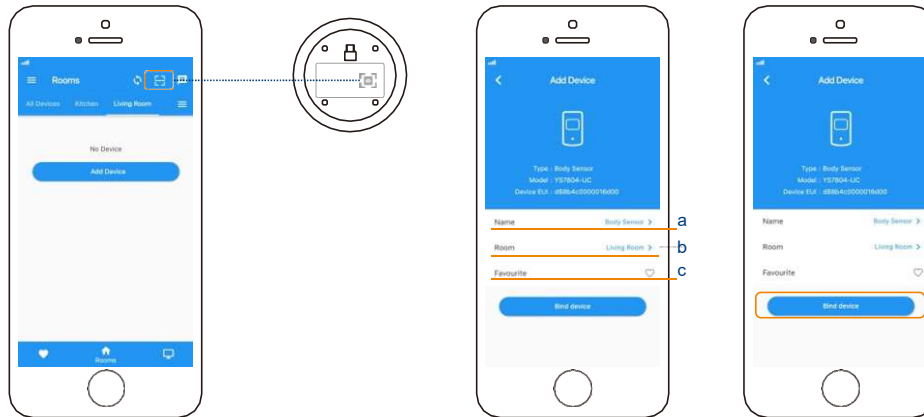

Step 4: Connect to the cloud

- Press the SET button once and your device will connect to the cloud automatically.

Note

- Make sure you hub is connected to internet.



Installation

Recommended Installation

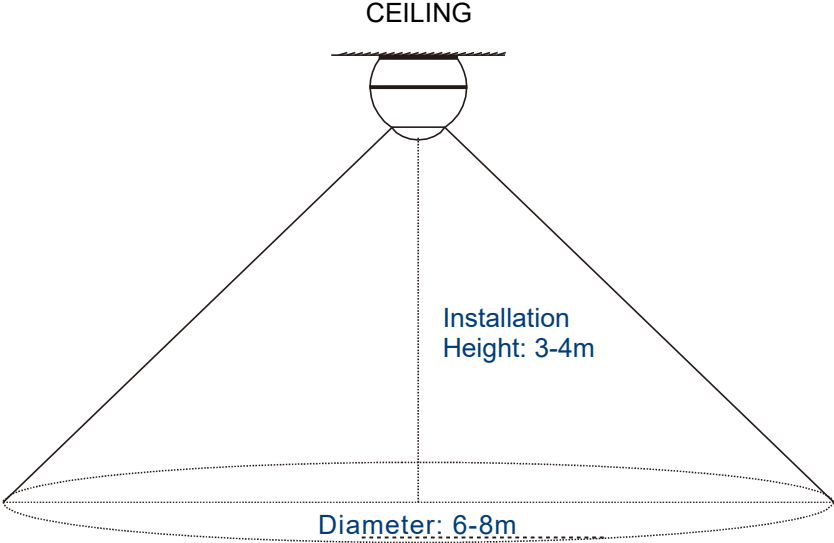

Ceiling and Wall Installation

- Please use the screws to stick the plate to wherever you want to monitor.
- Please connect the sensor to the plate.

Note

- Please add motion sensor to CHiQ App before you install it.

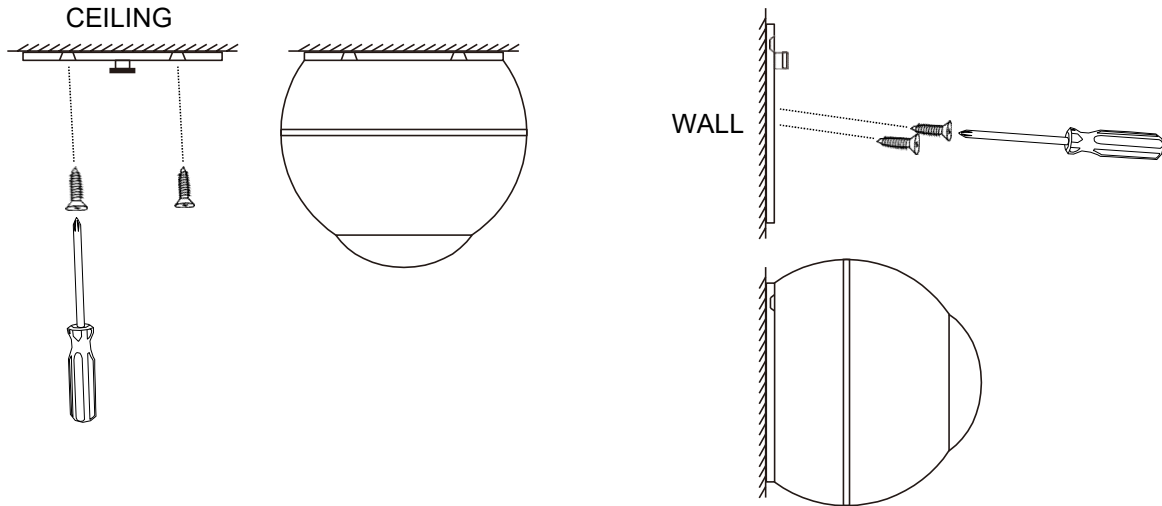

Using CHiQ App with Motion Sensor

Device Alert

- A movement is detected, an alert will send to your CHiQ account.

Note

- Interval between two alerts will be 1 minute.
- Device will not alert twice if movement is under continuously detection in 30 minutes.

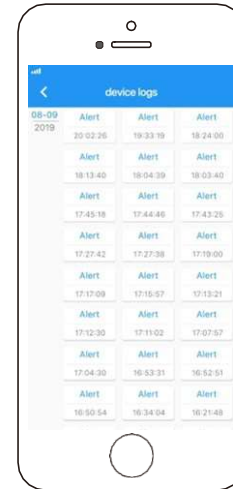

Using CHiQ App with Motion Sensor

Details

You can customize the name, set the room, add to/remove from favourite, check device history.

- a. **Name** - Name Motion Sensor.
- b. **Room** - Choose a room for Motion Sensor.
- c. **Favourite** - Click “  ” icon to add/remove from Favourite.
- d. **History** - Check the history log for the Motion Sensor.
- e. **Delete** – The device will be removed from your account.

- Tap the “Motion Sensor” in App to go to its controls.
- Tap the “  ” icon at the top-right corner to go to details.
- Tap the icon for each of the settings you want to personalize.

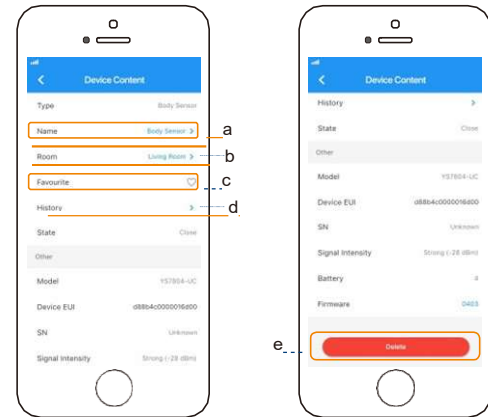

Automation

Automation allows you to set up “If This Then That” rules so the devices could act automatically.

- Tap “Smart” to switch to Smart screen and tap “Automation”.
- Tap “ + ” to create an automation.
- To set an Automation, you will need to set a trigger time, local weather condition, or choose a device with certain stage as a triggered condition. Then set one or more devices, scenes to be executed.

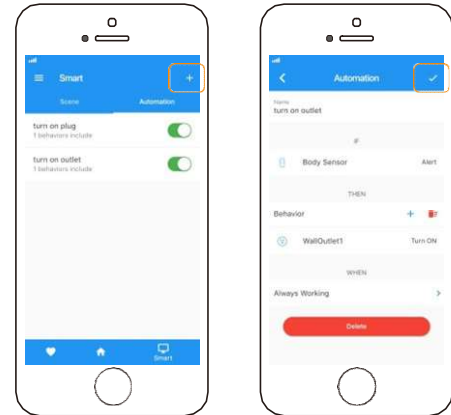

CHiQ Control

CHiQ Control is our unique “device to device” control technology. Under CHiQ Control, the devices could be controlled without internet or Hub. Device which send out command is called controller (Master). Device which receive command and act accordingly is called responder (Receiver).

You will need to set it up physically.

Pairing

- Find a motion sensor as controller (Master). Hold the set button for 5-10 seconds, the light will flash green quickly.
- Find an action device as responder (Receiver). Hold the power/set button for 5-10 seconds, the device will enter the pairing mode.
- After pairing succeed, the light will stop flashing.
- When the motion is detected, the responder will turn on as well.

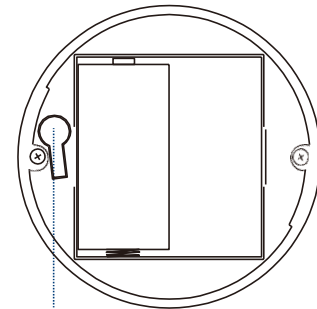

SET BUTTON

Un-pairing

- Find the controller (Master) motion sensor. Hold the set button for 10-15 seconds, the light will flash red quickly.
- Find the responder (Receiver) action device. Hold the power/ set button for 10- 15 seconds, the device will enter the un-pairing mode.
- The above two devices will unpair by themselves and the light stops flashing.
- After unbundling, when the motion is detected, the responder will no longer turn on.

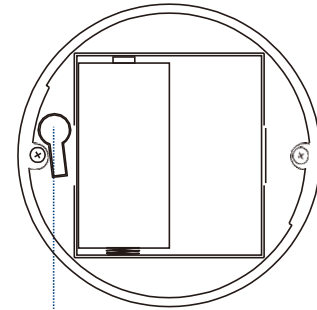

SET BUTTON

Responder List

- CH6602-UC CHiQ Plug
 - CH6604-UC CHiQ Plug Mini
 - CH5705-UC In-wall Switch
 - CH6704-UC In-wall Outlet
 - CH6801-UC Smart Power Strip
 - CH6802-UC Smart Switch
- Continuously updating...

CHiQ Control Diagram

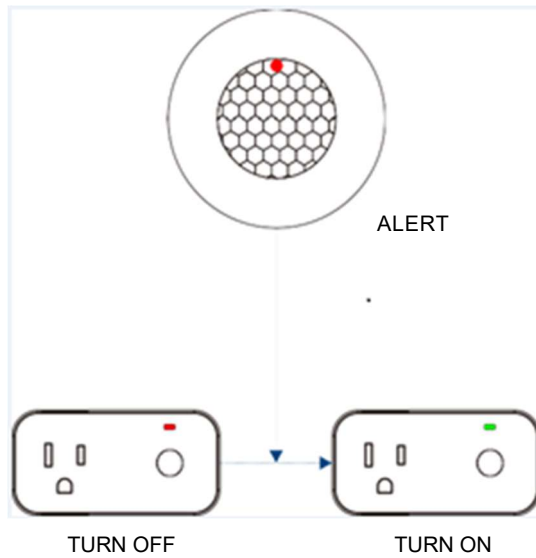

PAIRED

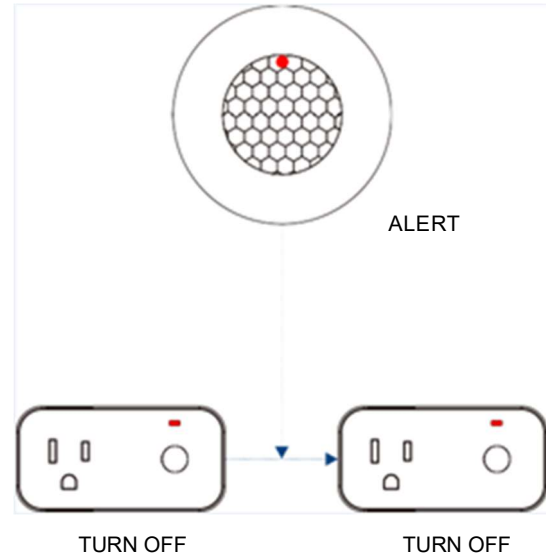

UNPAIRED

Maintaining the Motion Sensor

Firmware Update

To ensure our customer have the best user experience, we highly recommend you could update our newest version firmware.

- Tap the “Motion Sensor” in App to go to its controls.
- Tap the “⋮” icon at the top-right corner to go to details.
- Tap “Firmware”.
- The light will be slowly blinking green during the update and stop blinking when the update done.

Note

- Only the Motion Sensor that is currently reachable and has an available update will be shown on the Details screen.



Factory Reset

Factory reset will erase all your settings and bring it back to default. After the factory reset, your device will be still in your CHiQ account.

- Hold the set button for 20-25 seconds until the LED blinks red and green alternately. Factory
- reset will be done when the light stops flashing.

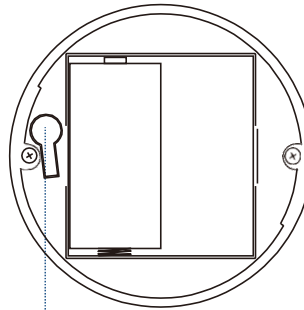

SET BUTTON

Specifications

Voltage: 3V DC (1-CR123A battery)

Detection Angle: 360° (Ceiling), 120° (Wall)

Installation Height: 3m (Ceiling), 1.5m (Wall)

Environment: Operating temperature: 0°C~50°C
(32°F~122°F)
Operating humidity: 0%~95% non-condensing

Troubleshooting

Problem	Possible Reason	Solution
Detection not work.	Temperature is too low or too high.	The most suitable temperature will be 25°C(77°F).
No alert or light.	Motion sensor battery is dead.	Please replace the battery.
Motion sensor is offline.	Hub is offline.	Please reconnect your hub to the Internet and press the set button of Motion Sensor once.
	Hub is powered off.	Please power on the hub again and press the set button of Motion Sensor once.
	Motion sensor battery is dead.	Please replace the battery.
	Device malfunction.	Please contact customer service.
LED blinking, no alert.	Notification has been turned off in CHIQ App.	Please turn notification on in the setting page of CHIQ App.
Alert received in App but no LED blinking.	Product is defective.	Please contact our customer service.

**If you are unable to get your product working,
please contact our customer service during business hours.**

US Live Tech Support: 1-408-9700349 M-F 9am - 5pm PST

Email: crl@Changhong.us

Changhong Research Labs Inc. 3945 Freedom Circle, Suite 320, Santa Clara,
CA 95054

WARRANTY 2 Years Limited Electrical Warranty

Changhong warrants to the original residential user of this product that it will be free from defects in materials and workmanship, under normal use, for 2 years from the date of purchase. User must provide a copy of original purchase receipt. This warranty Does Not Cover abuse or misused products, or products used in commercial applications. This warranty does not apply to motion sensors that have been improperly installed, modified, put to a use other than designed, or subjected to acts of God (such as floods, lightning, earthquakes, etc.). This warranty is limited to repairing or replacing of this motion sensor only at Changhong's sole discretion. Changhong will NOT be liable for the cost of installing, removing, nor reinstalling this product, nor direct, indirect, or consequential damages to persons or property resulting from the use of this product. This warranty only covers the cost of replacement parts or replacement units, it does not cover shipping & handling fees.

To implement this warranty please give us a call during business hours at 1-408-9700349 or visit www.Changhong.us.

Copyright 2019. Changhong Research Labs Inc. All rights reserved.

FCC Statement

This equipment has been tested and found to comply with the limits for a Class B digital device, pursuant to part 15 of the FCC Rules. These limits are designed to provide reasonable protection against harmful interference in a residential installation. This equipment generates, uses and can radiate radio frequency energy and, if not installed and used in accordance with the instructions, may cause harmful interference to radio communications. However, there is no guarantee that interference will not occur in a particular installation. If this equipment does cause harmful interference to radio or television reception, which can be determined by turning the equipment off and on, the user is encouraged to try to correct the interference by one or more of the following measures:

- Reorient or relocate the receiving antenna.
- Increase the separation between the equipment and receiver.
- Connect the equipment into an outlet on a circuit different from that to which the receiver is connected.
- Consult the dealer or an experienced radio / TV technician for help.

This device complies with part 15 of the FCC Rules. Operation is subject to the following two conditions:

1) This device may not cause harmful interference.

2) This device must accept any interference received, including interference that may cause undesired operation. Any changes or modifications not expressly approved by the party responsible for compliance could void the user's authority to operate the equipment.

Note: The manufacturer is not responsible for any radio or TV interference caused by unauthorized modifications to this equipment. Such modifications could void the user's authority to operate the equipment.

FCC RF Radiation Exposure Statement

This equipment complies with FCC RF radiation exposure limits set forth for an uncontrolled environment. This device and its antenna must not be co-located or operating in conjunction with any other antenna or transmitter.

“To comply with FCC RF exposure compliance requirements, this grant is applicable to only Mobile Configurations. The antennas used for this transmitter must be installed to provide a separation distance of at least 20 cm from all persons and must not be co-located or operating in conjunction with any other antenna or transmitter.”